

- (1) Rebar must be 40,000 psi Strength
- (2) 6"x6" 6/6 Standard Gauge wire mesh
- (3) Concrete Strength: 5400 psi @ 28 days

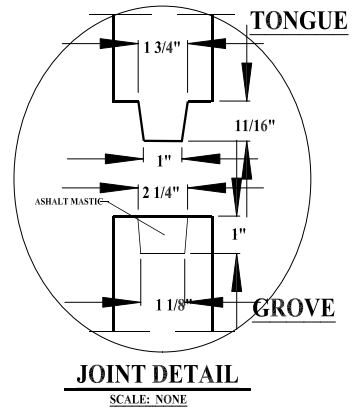

**3600 GALLON SINGLE COMPARTMENT TANK
SEPTIC / LIFT STATION**

COATE CONCRETE PRODUCTS

P. O. BOX 159, WEST MILTON, OH 45383

WEST MILTON PHONE: (937) 698-4181

OHIO WATS PHONE: (800) 762-4066

MODEL: 3600 GALLON LIFT TANK

MATERIAL: VIBRATED CONCRETE REINFORCED W/ 6X6" 6/6 WIRE MESH & #4 (1/2") REBAR

SCALE: 3/8" = 1'-0" UNLESS OTHERWISE NOTED

DR. BY: RVA

DATE: 04/17/17

DWG. No: 01-3600SC-A01

SHEET 1 OF 1

NOTES:

46 Gallons / Inch

DATE	REV.	LOC.	DESCRIPTION
------	------	------	-------------