

**ASSEMBLED TANK**

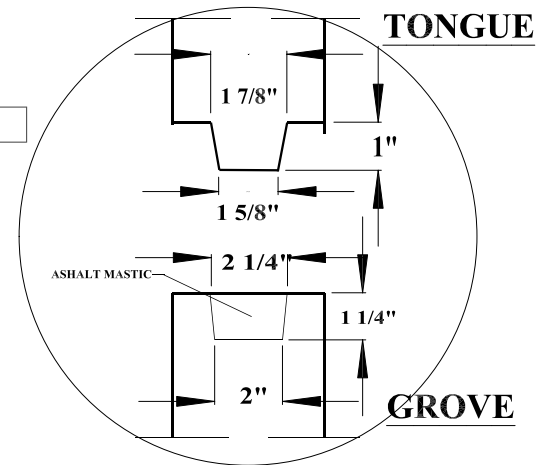

**JOINT DETAIL**

SCALE: NONE

**2000 Oil Interceptor**

**COATE CONCRETE PRODUCTS**

P. O. BOX 159, WEST MILTON, OH 45383

WEST MILTON PHONE: (937) 698-4181

OHIO WATS PHONE: (800) 762-4066

**MODEL: 2000 GALLON TANK**

**MATERIAL:** VIBRATED CONCRETE REINFORCED W/ 6X6" 10/10 WIRE MESH & #3 (3/8") REBAR

**SCALE:** 3/8" = 1'-0" UNLESS OTHERWISE NOTED

**DR. BY: RVA**

**DATE: 11/16/04**

**DWG. No: 01-2000SC-A01**

**SHEET 1 OF 1**

NOTES:

DATE	REV.	LOC.	DESCRIPTION