

**ASSEMBLED TANK**

4" Dia. Rubber Boot - Pipe Seals  
Both Ends (2) Req'd

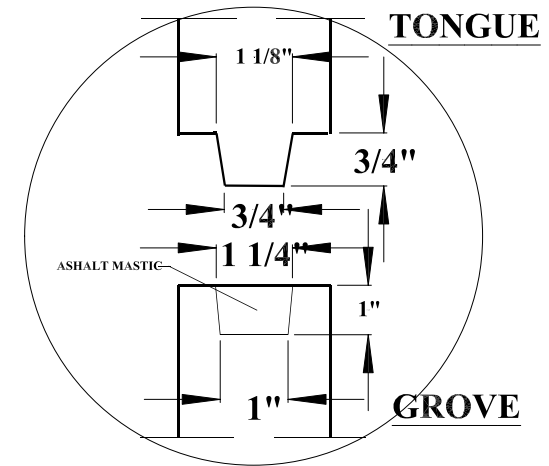
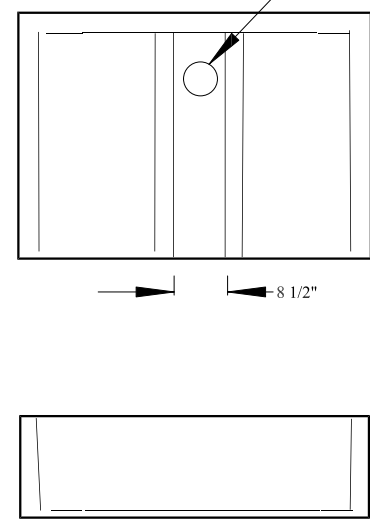
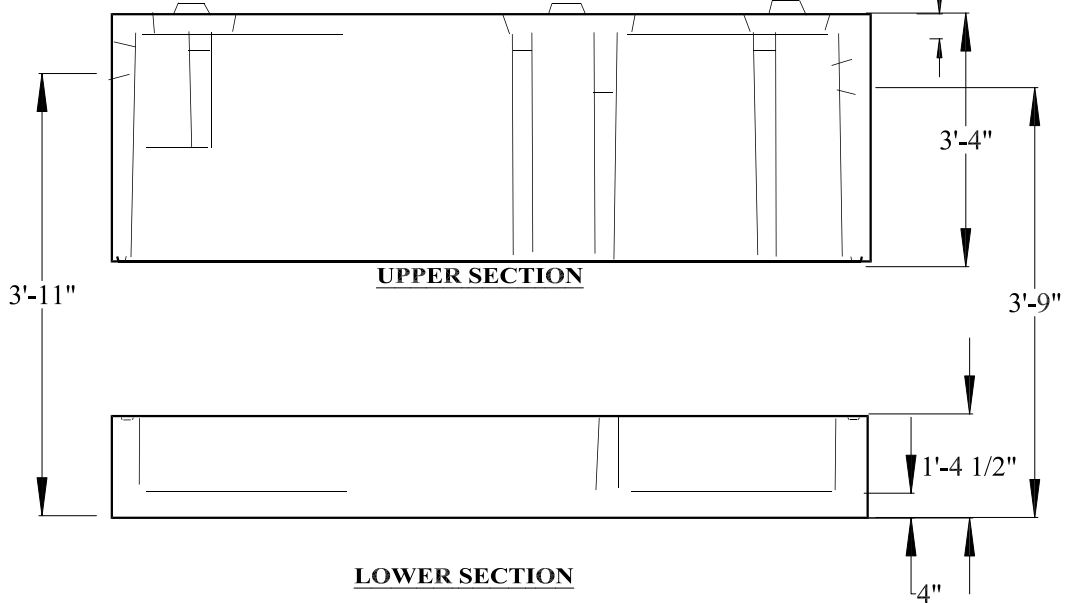

**JOINT DETAIL**

SCALE: NONE

**COATE CONCRETE PRODUCTS**  
**P. O. BOX 159, WEST MILTON, OH 45383**  
**WEST MILTON PHONE: (937) 698-4181**  
**OHIO WATS PHONE: (800) 762-4066**  
**MODEL: 1500 GALLON D.C. ROCK TANK**  
VIBRATED CONCRETE REINFORCED W/ 6X6" 10/10  
**MATERIAL: WIRE MESH & #3 (3/8") REBAR**  
**SCALE: 3/8" = 1'-0" UNLESS OTHERWISE NOTED**  
**DR. BY: RVA**                      **DATE: 10/14/97**  
**DWG. No: 02-1500RDC-A01**      **SHEET 1 OF 1**

NOTES:

DATE	REV.	LOC.	DESCRIPTION